

**GENERAL NOTES:**

1. ANY LIFT EXCEEDING 6' MUST BE ADDED TO HEAD LOSSES ON VACUUM MAIN AND SERVICE LINE TO DETERMINE IF SUFFICIENT VACUUM HEAD IS AVAILABLE.
2. ALL MATERIALS AND HARDWARE FOR INSTALLING VALVE, AND TESTING BY CONTRACTOR, EXCEPT VALVE TO BE INSTALLED BY OWNER, ALL PVC FITTINGS TO BE GLUED EXCEPT WHERE NOTED. DRILL HOLE IN WALL FOR MOUNTING SCREW FOR SUMP BREATHER.

**CONSTRUCTION NOTES:**

- A. SUMP BREATHER ASSEMBLY (ONE PER VALVE).
- B. 1'-6" I.D. PVC PIPE 1'-0" LONG MAY BE USED TO FORM SUMP AREAS.
- C. MASS CONCRETE.
- D. SEWER MANHOLE FRAME & COVER PER C.O.A. STD. DWG. 2110
- E. CONCRETE COLLAR PER C.O.A. STD. DWG. 2461.
- F. PRECAST CONCRETE FLAT TOP FOR MANHOLE WITH 2'-0" DIA. OPENING.
- G. 2" PVC SENSOR CAP SUPPLIED WITH VALVE.
- H. 2" PVC SENSOR PIPE.
- I. PRECAST CONCRETE BOTTOM IN MANHOLE SECTION
- J. 3" STREET ELL TOUCHING BASE OF SUMP WITH PLAIN END. NO CONNECTION.
- K. VALVE AND PIPING REMOVED FOR CLARITY.
- L. 18" DIAMETER SUMP (2).
- M. LOCATION OF LID.
- N. USE 4'-0" I.D. CONCRETE MANHOLE SECTIONS. ADDITIONAL SECTIONS MAY BE ADDED TO ALLOW FOR EXCESSIVE HEAD. GRAVITY LINES OR FOR ADDED STORAGE CAPACITY.
- O. 3" VACUUM SERVICE LINES MUST (EACH) CONNECT DIRECTLY TO A 6" MINIMUM SEPARATION AT MAIN. SERVICE LINES FITTED WITH STANDARD FLEXIBLE CONNECTORS AT THE HOLE IN THE MANHOLE SECTION TO INSURE THAT THE BUFFER TANK IS WATER TIGHT.
- P. MINIMUM 6" GRAVITY LINE WITH MATCHING VENT. MINIMUM 20' FROM BUFFER TANK. CONNECT 6" LINE TO 12" X 6" REDUCER. CONNECT REDUCER TO 12" PIPE ENTERING MANHOLE. CENTER 12" PIPE OVER CENTER DIVIDER WALL. C. 12" LINE SHALL BE FITTED WITH STANDARD FLEXIBLE CONNECTORS AT THE HOLE TO INSURE THAT BUFFER TANK IS WATERTIGHT.
- Q. SHAPE SLOPED CONCRETE TO DISTRIBUTE FLOW EVENLY BETWEEN SUMPS.
- R. GRAVITY INLET MUST BE LOCATED BETWEEN THE VACUUM SERVICE LINE AND THE START OF SLOPE TO SUMP.
- S. 3" "D" MODEL VALVE, BY AIRVAC OR EQUAL, TO BE INSTALLED BY OWNER

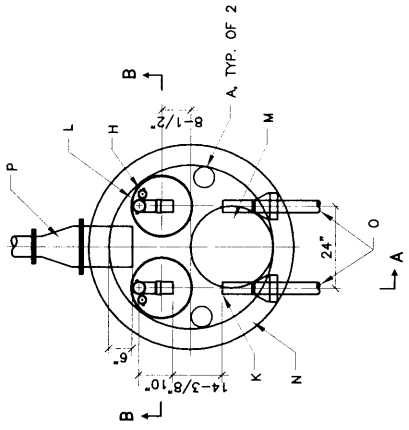

PLAN

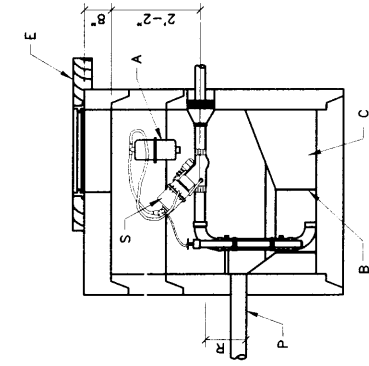

SECTION A-A

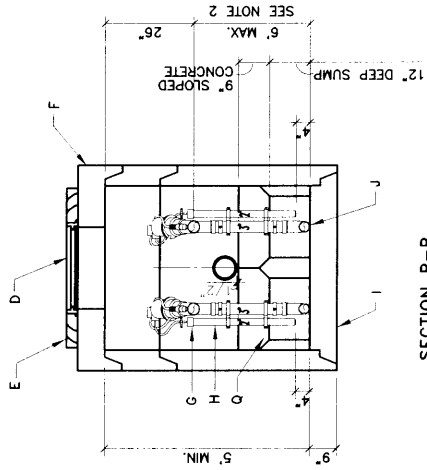

SECTION B-B

REVISIONS	NM APWA
	VACUUM SEWER STANDARDS DUAL BUFFER TANK 60 GALLON PER MINUTE MAX. FLOW DWG. 2168 FEB. 2006