

GENERAL NOTES:

1. THESE DETAILS ARE PROVIDED FOR HIGH TRAFFIC VOLUME PRIVATE ENTRANCES TO COMMERCIAL SITES AND THE LIKE, IN LIEU OF STANDARD DRIVEPADS.

CONSTRUCTION NOTES:

- A. INCLUDE QUARTER POINT ELEVATIONS. SEE STD. DETAIL DWG. 2420.
- B. WHERE INTERIOR SIDEWALK CONNECTION IS TO BE PROVIDED - CONSTRUCT CURB ACCESS RAMPS AS PER STD. DETAIL DWG. 2418 & 2441.
- C. INITIAL GRADE TO BE 4% OR LESS WHEN CONNECTING TO COLLECTOR OR ARTERIAL STREETS, 6% OR LESS WHEN CONNECTING TO LOCAL STREETS.
- D. INCLUDE ELEVATIONS AT EACH END OF CURB RETURN AND INTERSECTIONS OF PROJECTED FLOWLINES. SEE STD. DWG. 2420.
- E. AT PROPERTY LINE CONSTRUCT HEADER CURB. SEE STD. DWG. 2415.
- F. IF SIDEWALK IS AGAINST CURB THE SIDEWALK SHOULD BE TRANSITIONED TO KEEP THE CURB ACCESS RAMP IN THE LOCATION SHOWN.
- G. 1/2" EXPANSION JOINT MATERIAL.
- H. THEORETICAL FACE OF CURB OR FLOWLINE.

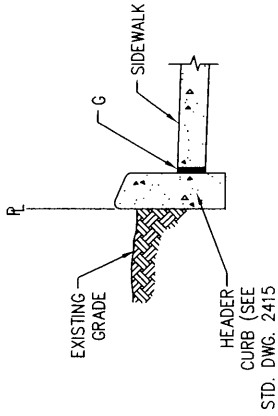

SECTION A-A

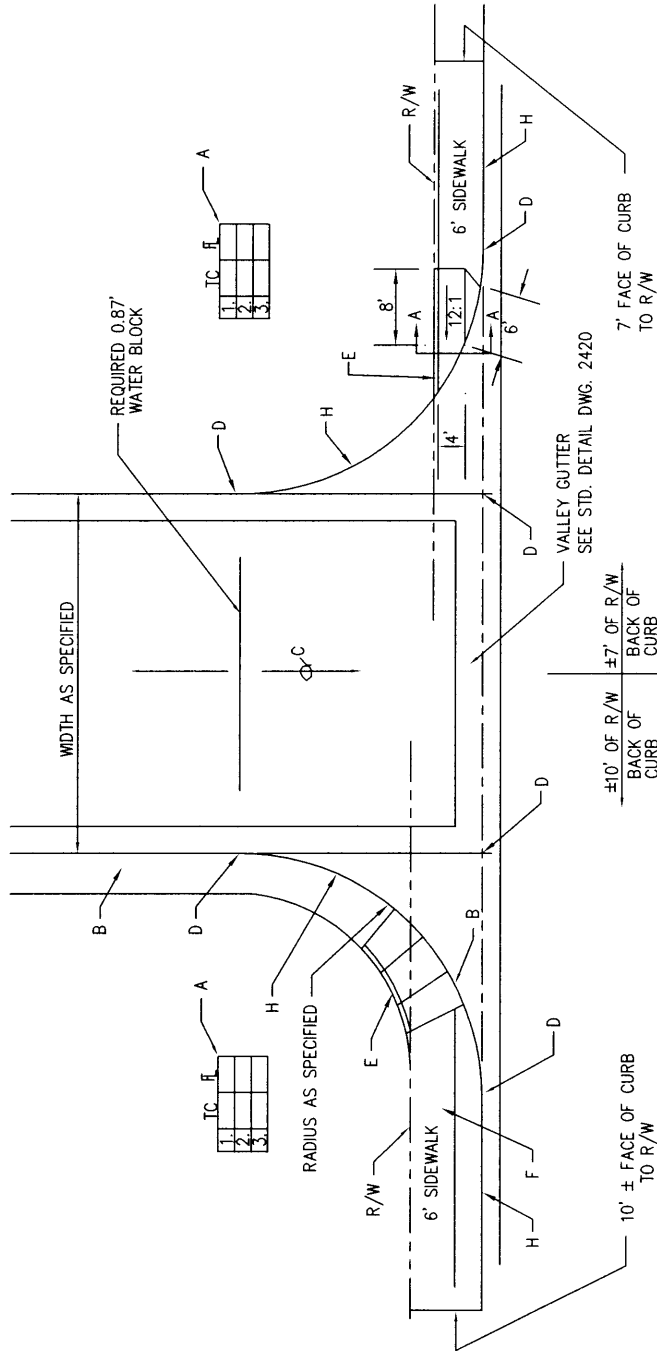

PRIVATE ENTRANCE

NM APWA

REVISIONS

1/91
11/14/91
4/4/94

PAVING

PRIVATE ENTRANCE DETAILS--
ILLUSTRATING TWO SEPRATE R/W CONDITIONS
DWG. 2426

AUG. 1986