

G Membrane Vertical Termination
Scale: 6" = 1'-0"

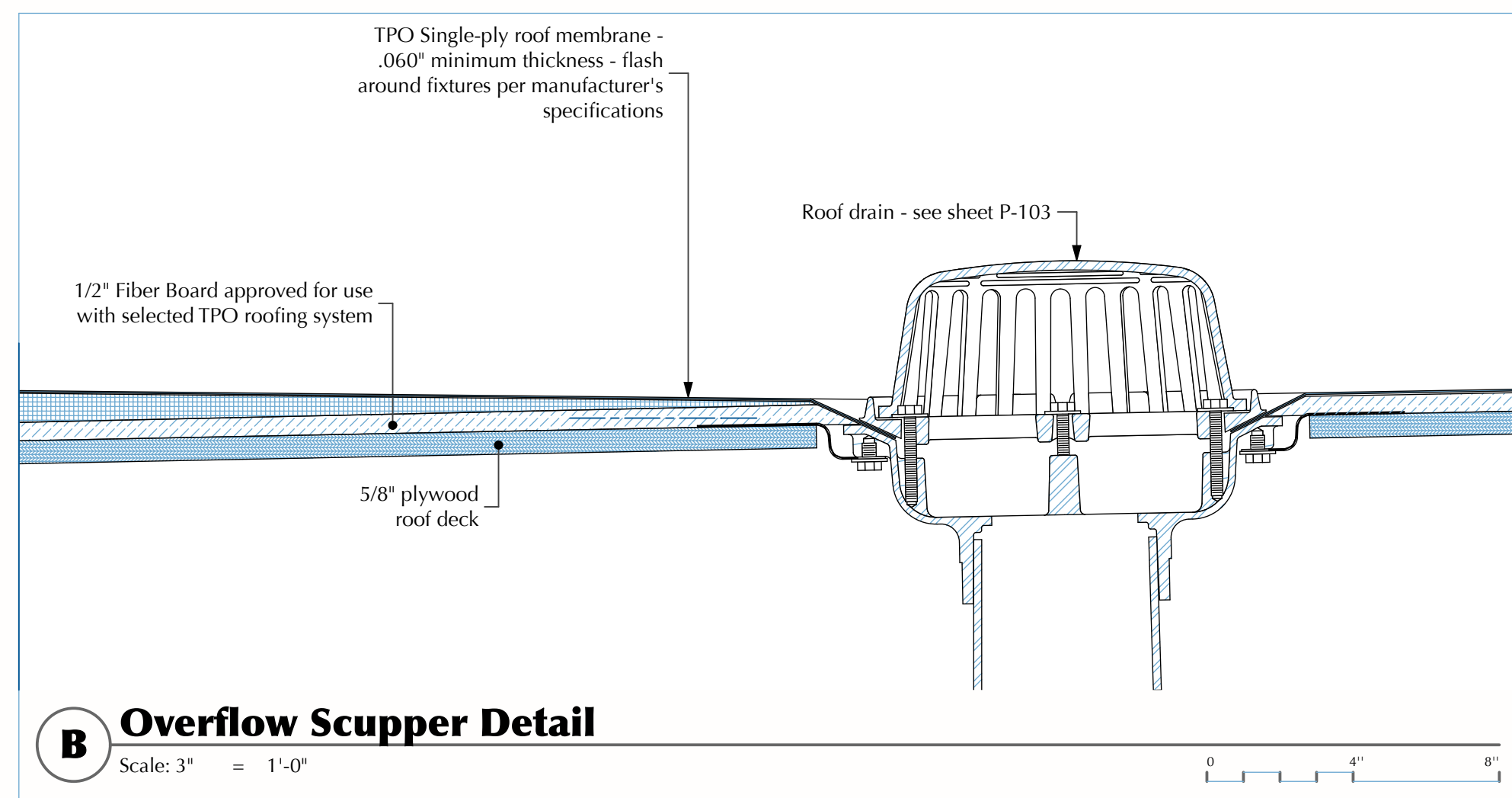

B Overflow Scupper Detail
Scale: 3" = 1'-0"

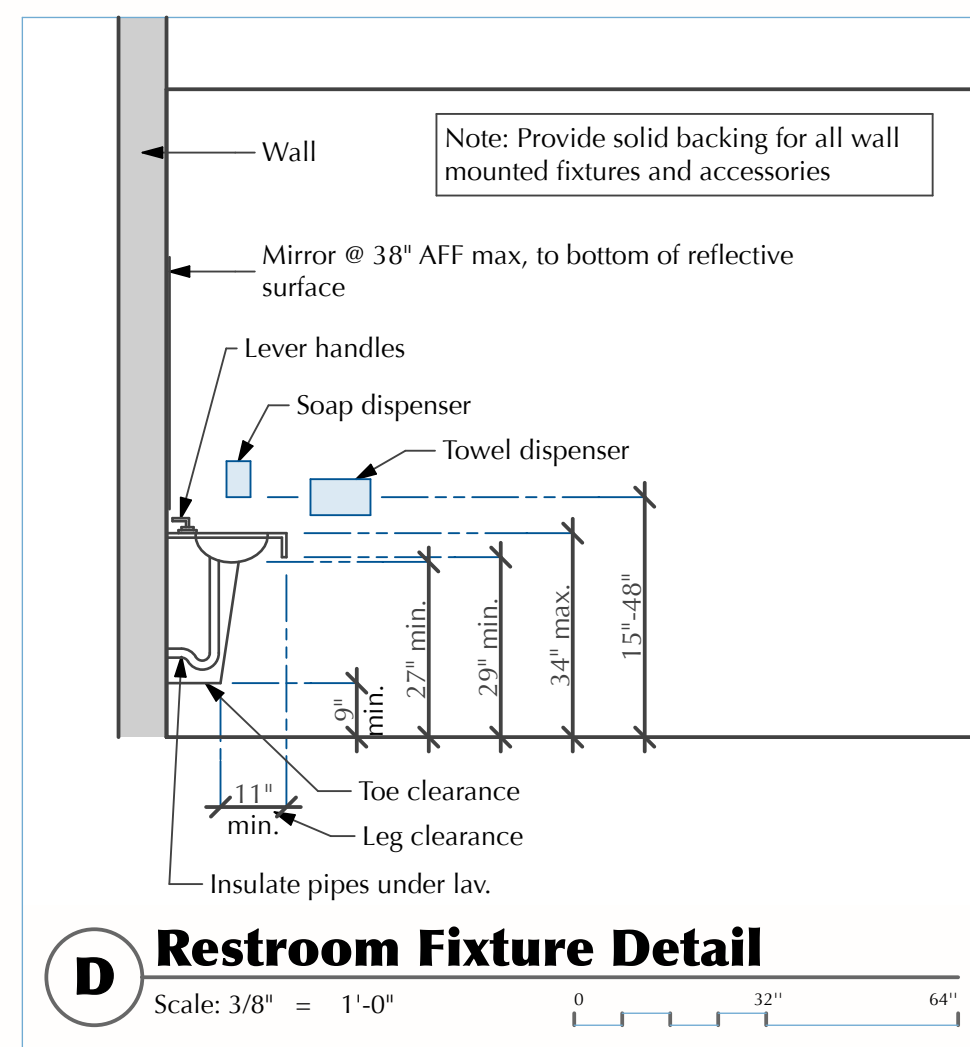

D Restroom Fixture Detail
Scale: 3/8" = 1'-0"

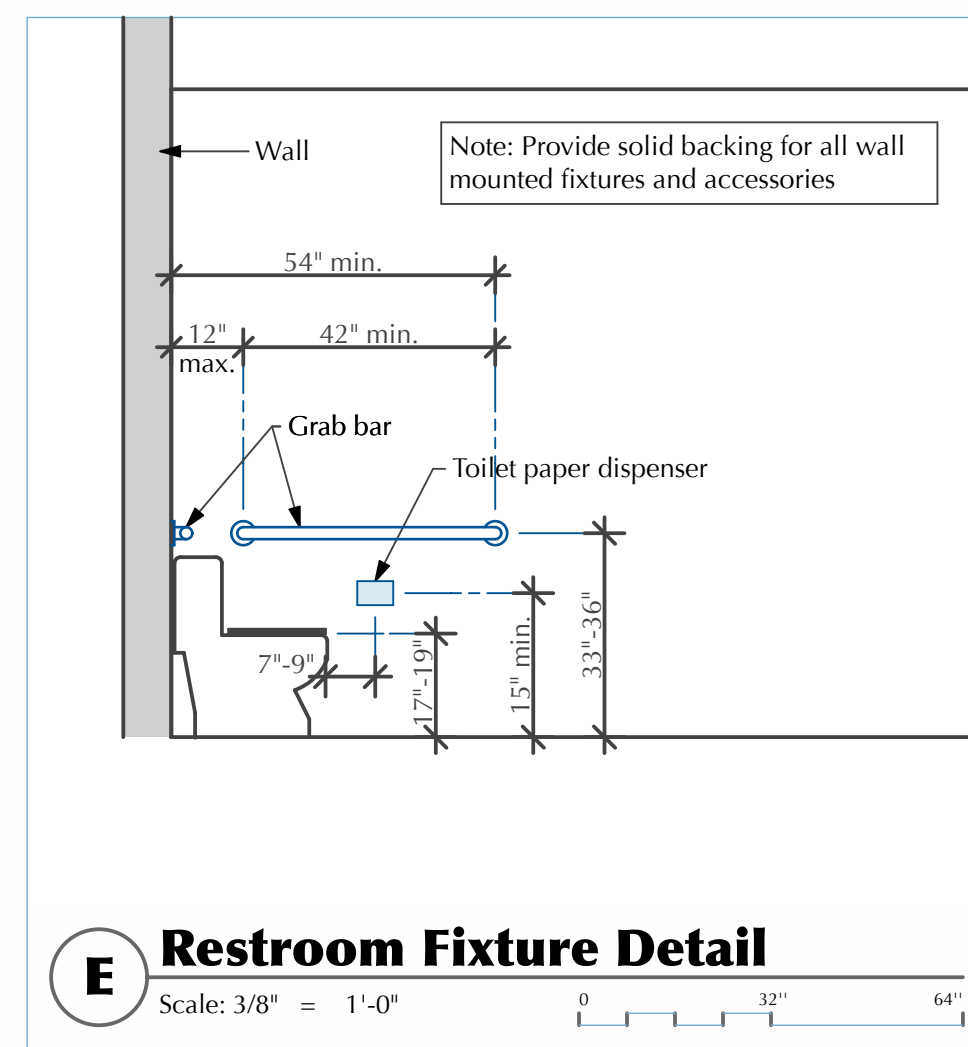

E Restroom Fixture Detail
Scale: 3/8" = 1'-0"

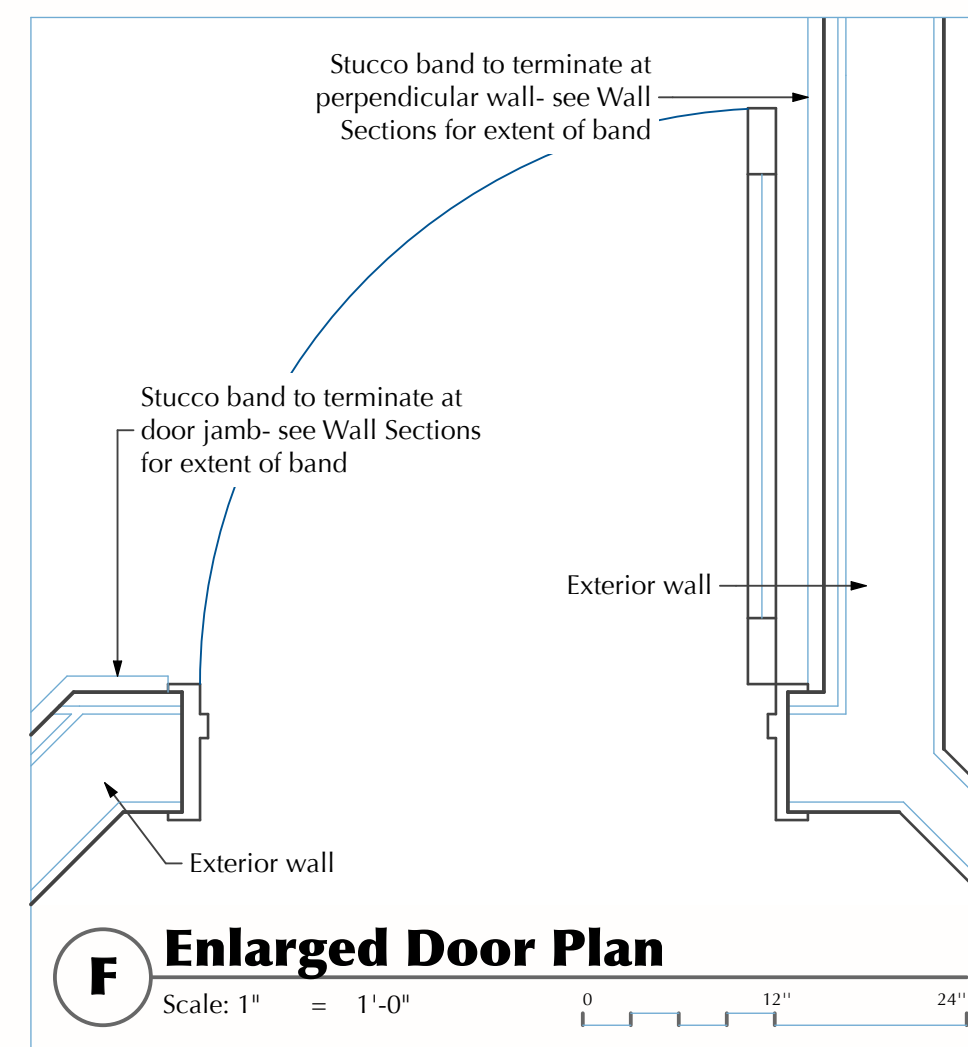

F Enlarged Door Plan
Scale: 1" = 1'-0"

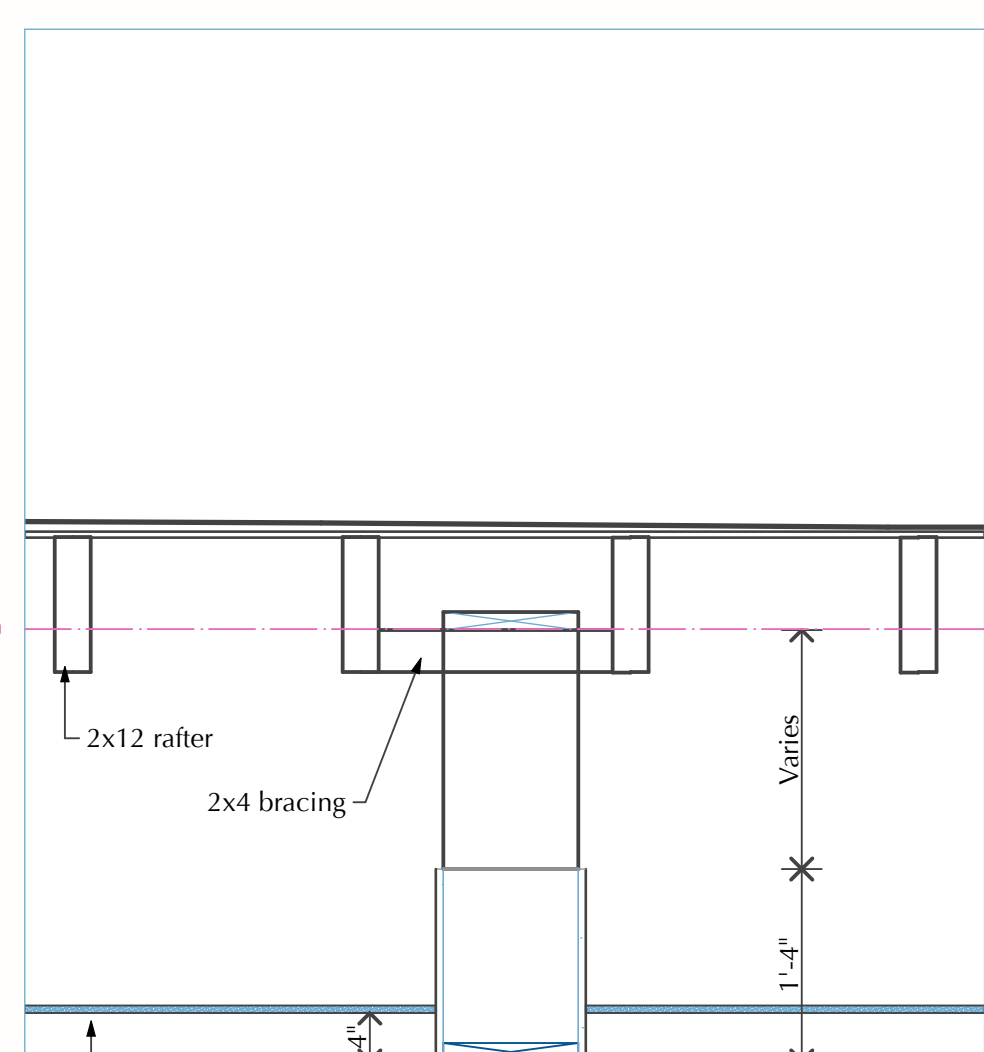

N Ceiling Soffit Detail
Scale: 3/4" = 1'-0"

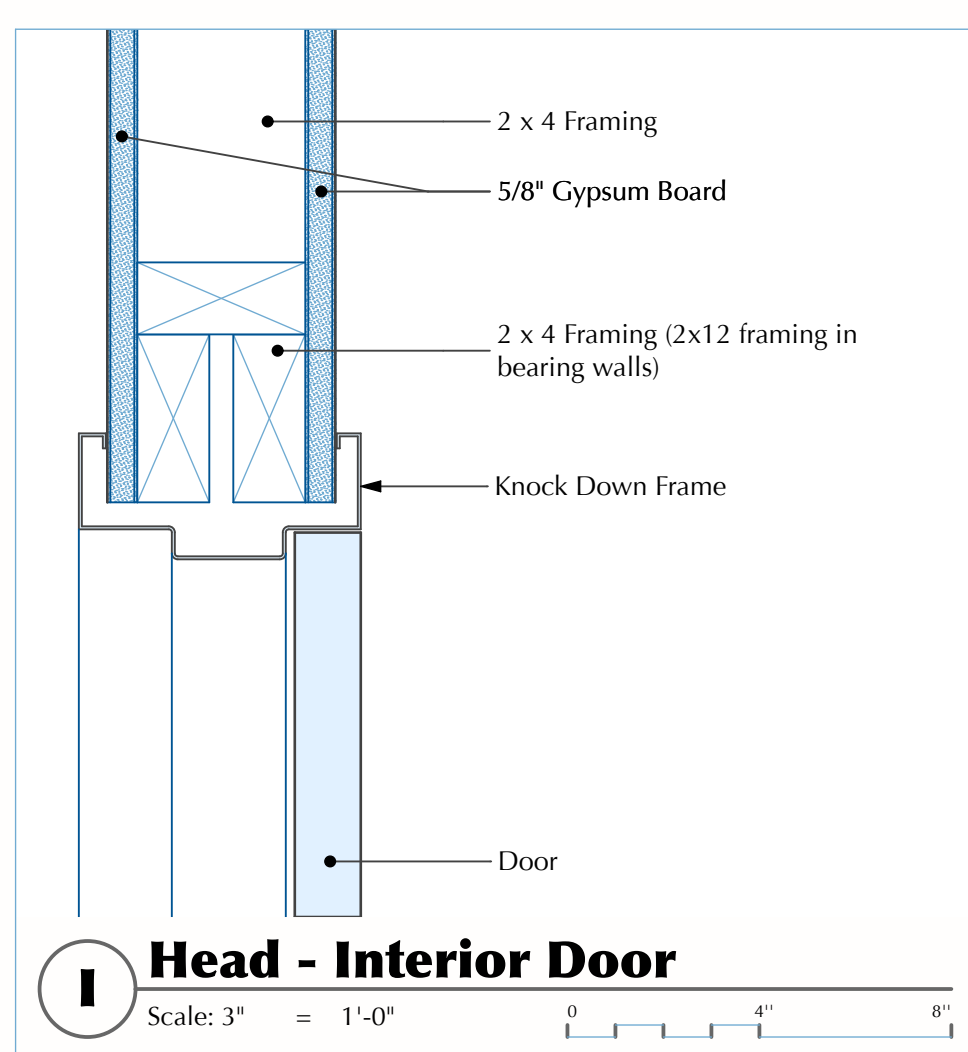

I Head - Interior Door
Scale: 3" = 1'-0"

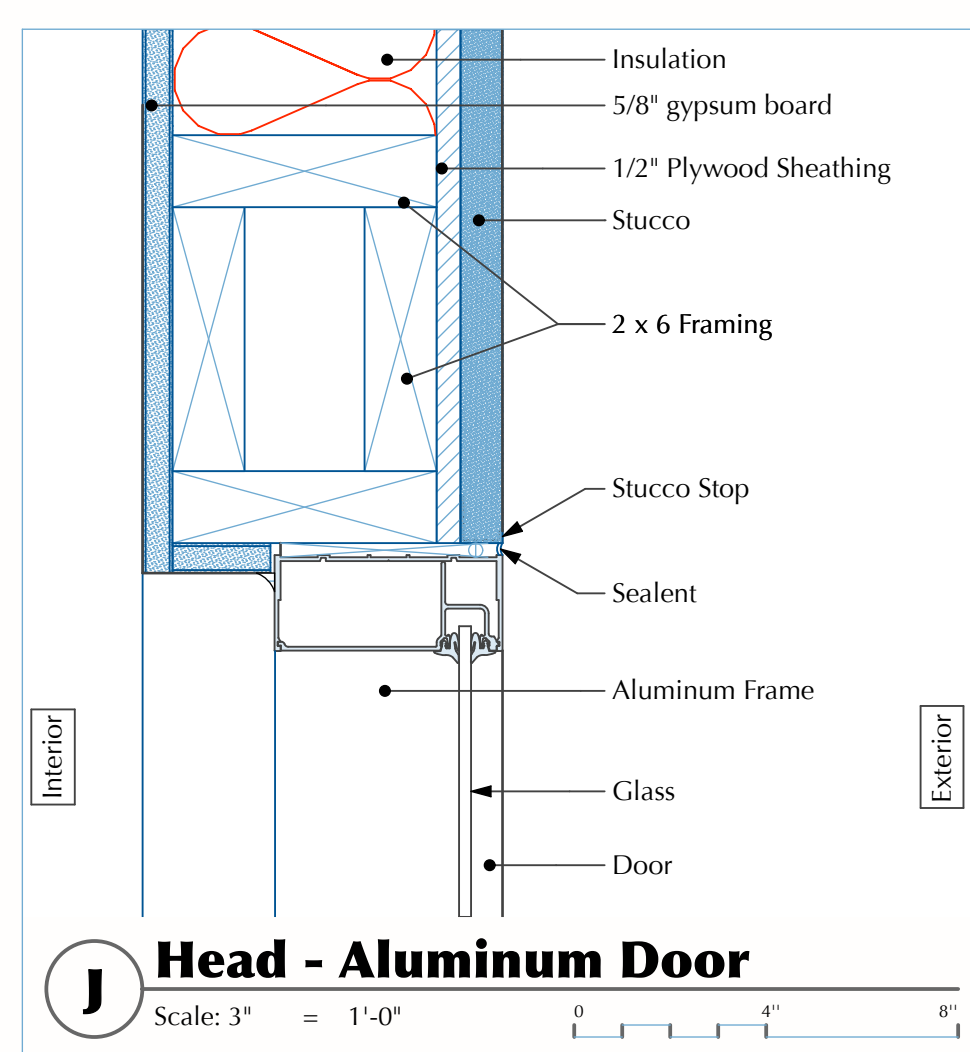

J Head - Aluminum Door
Scale: 3" = 1'-0"

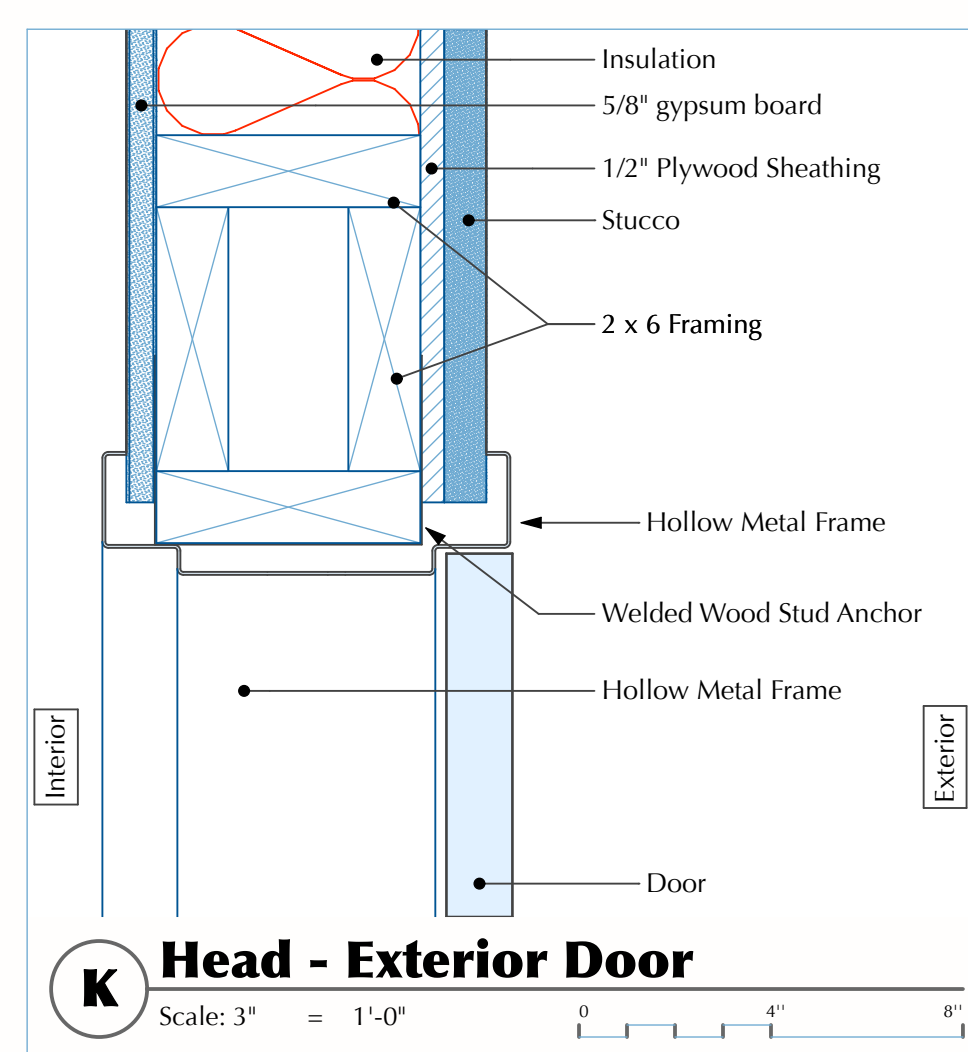

K Head - Exterior Door
Scale: 3" = 1'-0"

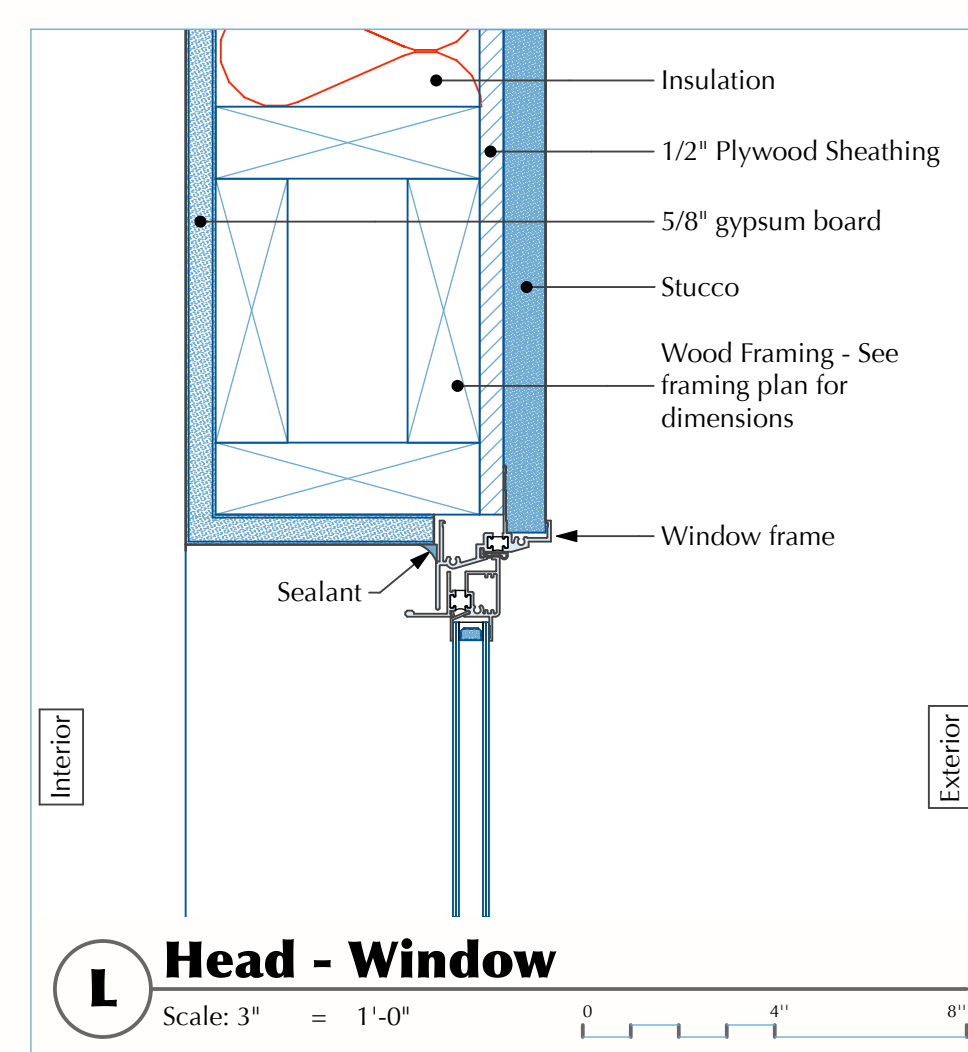

L Head - Window
Scale: 3" = 1'-0"

- Vertical Hangers** - Suspension wires shall not be smaller than No. 12 gauge spaced at 4' O.C. or No. 10 gauge spaced at 5' O.C. along each main runner. Each vertical wire shall be attached to the ceiling suspension member and to the support above with a minimum of three turns. Any connection device at the supporting construction shall be capable of carrying not less than 100 pounds. Suspension wires shall not hang more than 1-in-6 out-of-plumb unless counter sloping wires are provided. Wires shall not attach to or bend around interfering material or equipment. A trapeze or equivalent device shall be used where obstructions preclude direct suspension. Trapeze suspensions shall be a minimum of back-to-back 1-1/4" cold-rolled channels for spans exceeding 48".
- Perimeter Hangers** - The perimeter ends of each cross runner and main runner shall be supported independently a maximum of 8" from each wall or ceiling discontinuity with No. 12 gauge wire or approved wall support. These wires shall not hang more than 1-in-6 out-of-plumb and must be connected to an adjacent wall or to the structure above.
- Lateral Force Bracing** - Where design calculations by a structural engineer are not provided, horizontal restrains shall be effected by four No. 12 gauge wires secured to the main runner within 2" of the cross runner intersection and splayed 90° from each other at an angle not exceeding 45° from the plane of the ceiling. A strut fastened to the main runner shall be extended to and fastened to the structural members supporting the roof or floor above. The strut shall be adequate to resist the vertical component induced by the bracing wires, these horizontal restraint points shall be placed 12" on center in both directions with the first point within 6" from each wall. Attachment of the restraint wires to the structure above shall be adequate for the load imposed. Lateral force bracing members shall be spaced a minimum of 6" from all horizontal piping or duct work that is not provided with bracing restrains for horizontal forces. Bracing wires shall be attached to the grid and to the structure in such a manner that they can support a design load of not less than 200 pounds or the actual design load, with a safety factor of 2, whichever is greater.
- Perimeter Members** - Wall angles or channels shall be considered as aesthetic closures and shall have no structural value assessed to them or their method of attachment to the walls. Ends of main runners and cross members shall be tied together to prevent them from spreading.
- Attachment Of Members To The Perimeter** - To facilitate installation, main runners and cross runners may be attached to the perimeter member at two adjacent walls with clearance between the wall and the runners maintained at the other two walls.

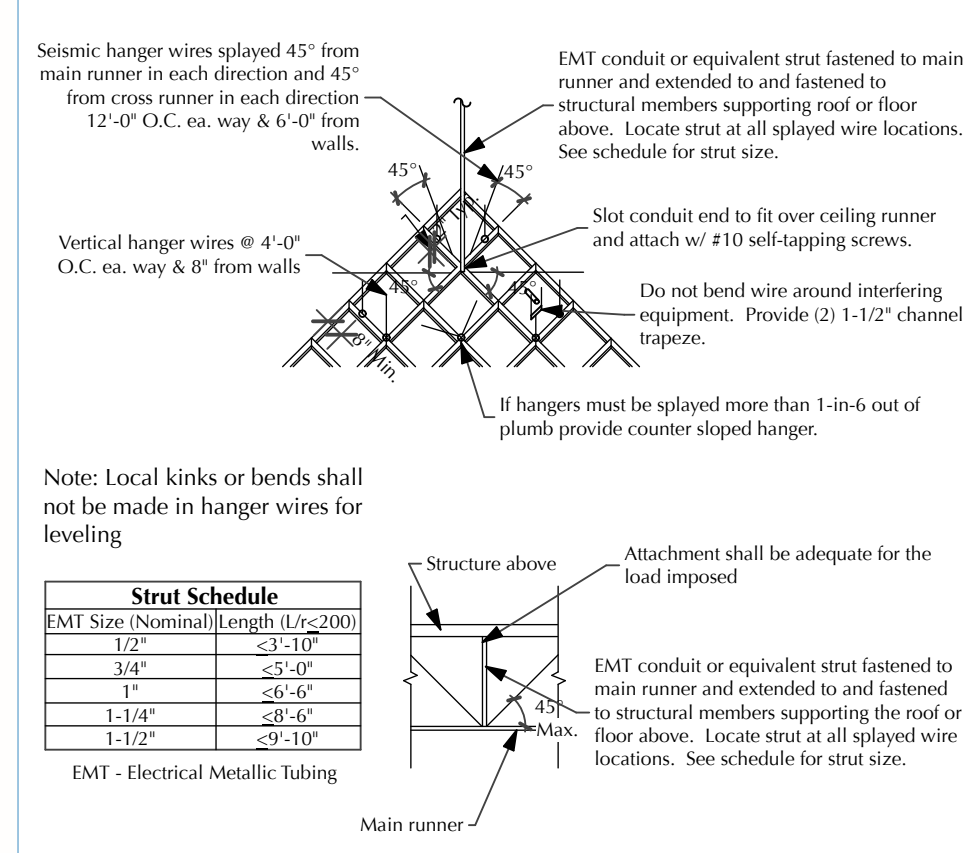

S Ceiling Brace
Not To Scale

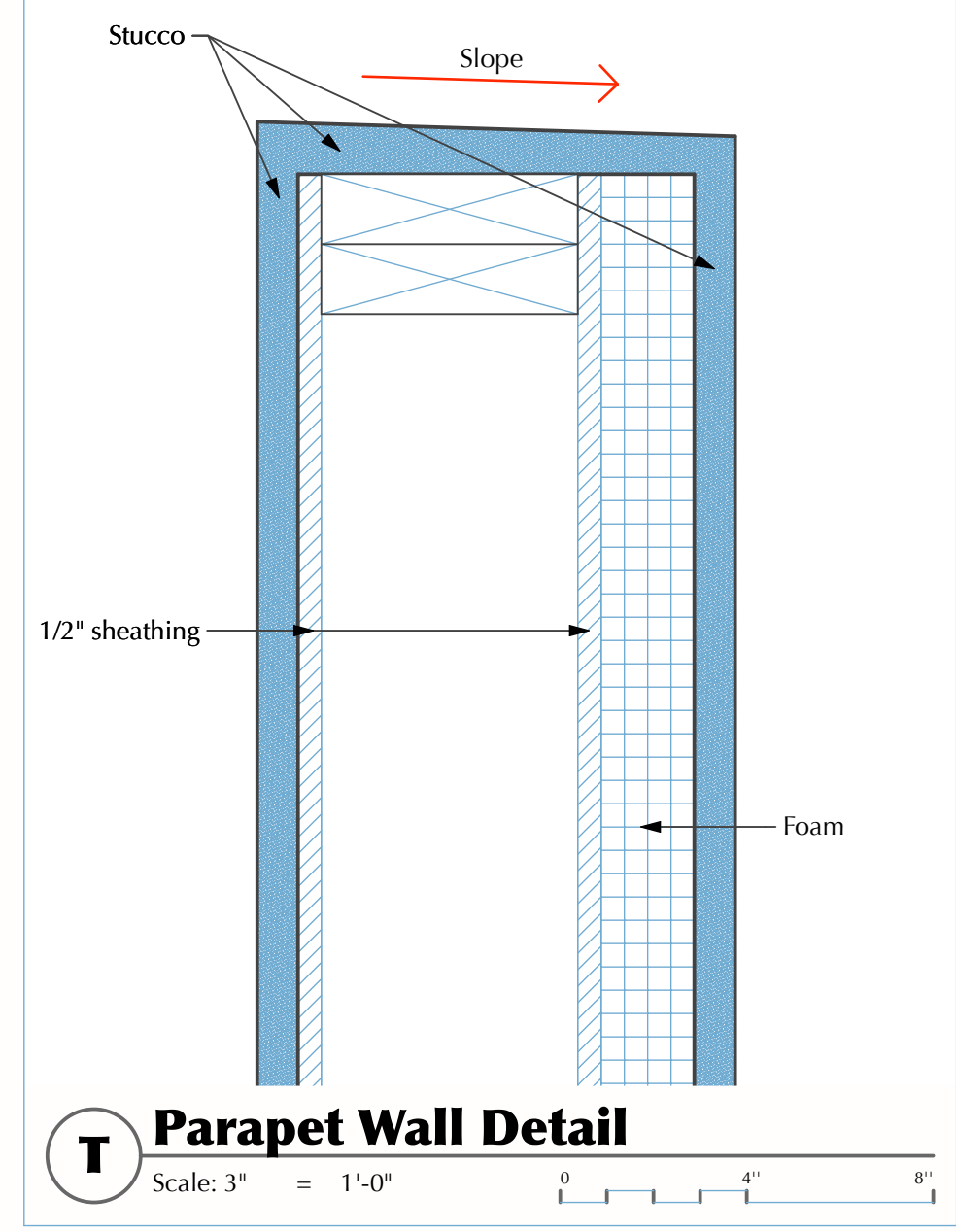

T Parapet Wall Detail
Scale: 3" = 1'-0"

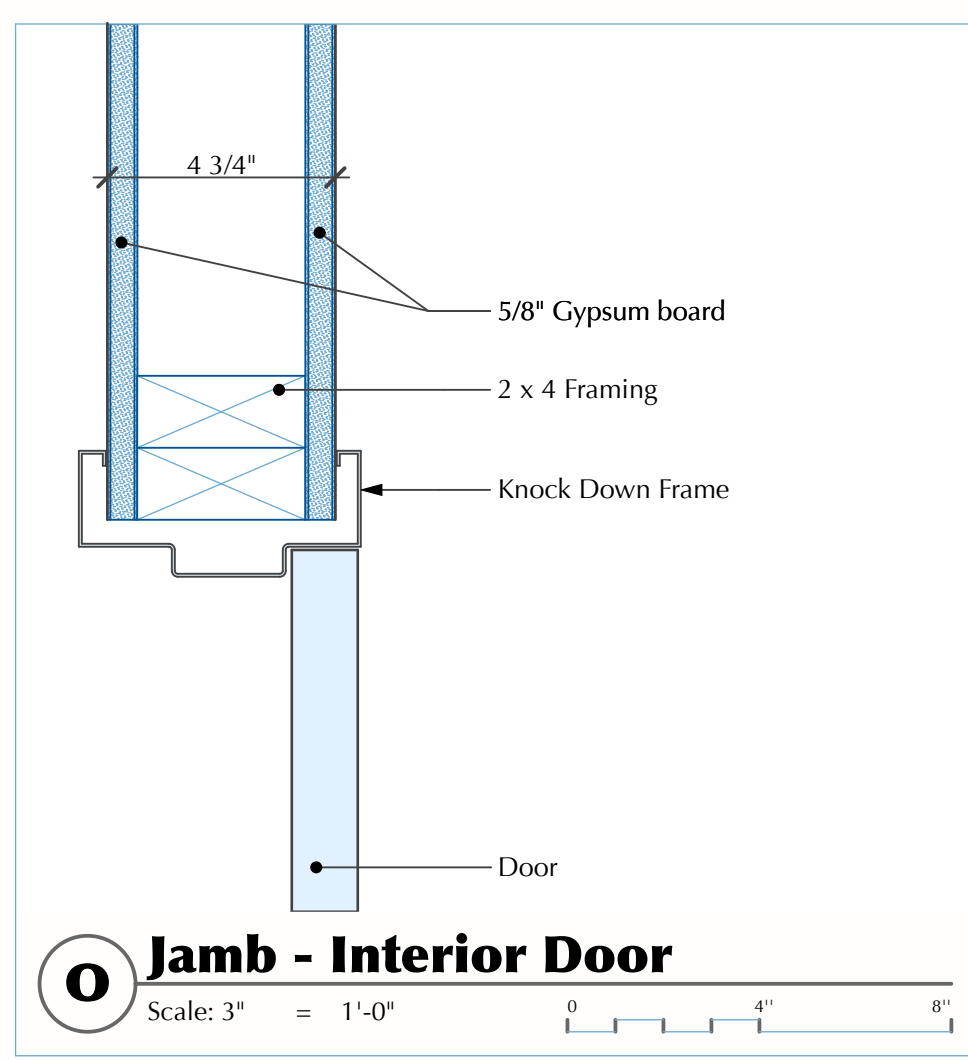

O Jamb - Interior Door
Scale: 3" = 1'-0"

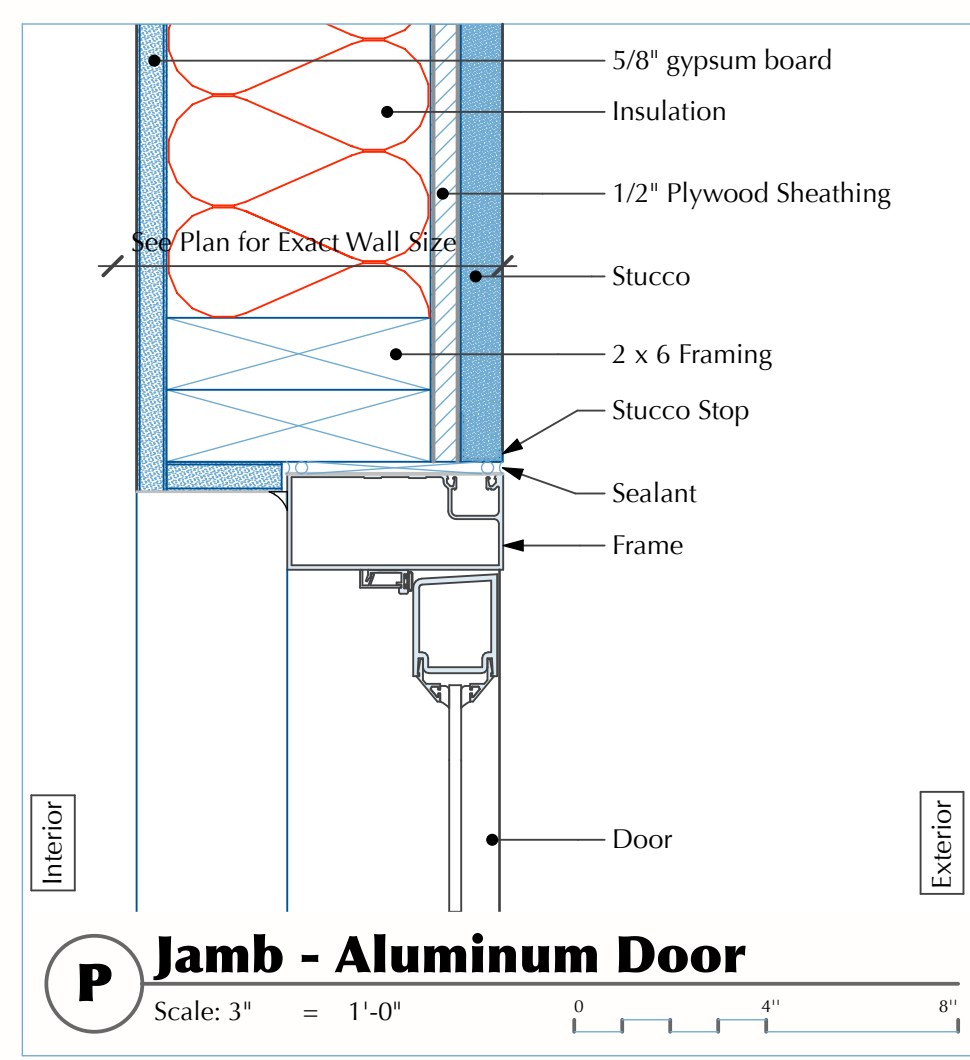

P Jamb - Aluminum Door
Scale: 3" = 1'-0"

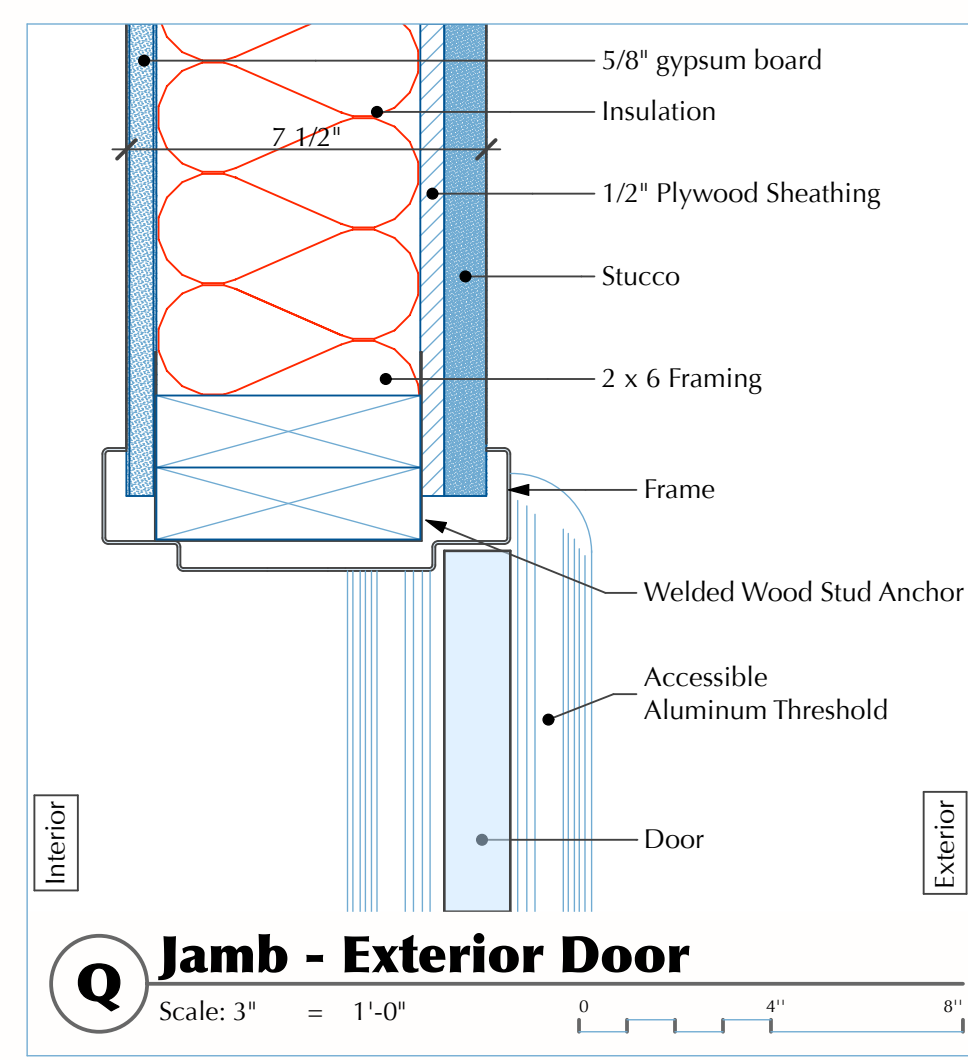

Q Jamb - Exterior Door
Scale: 3" = 1'-0"

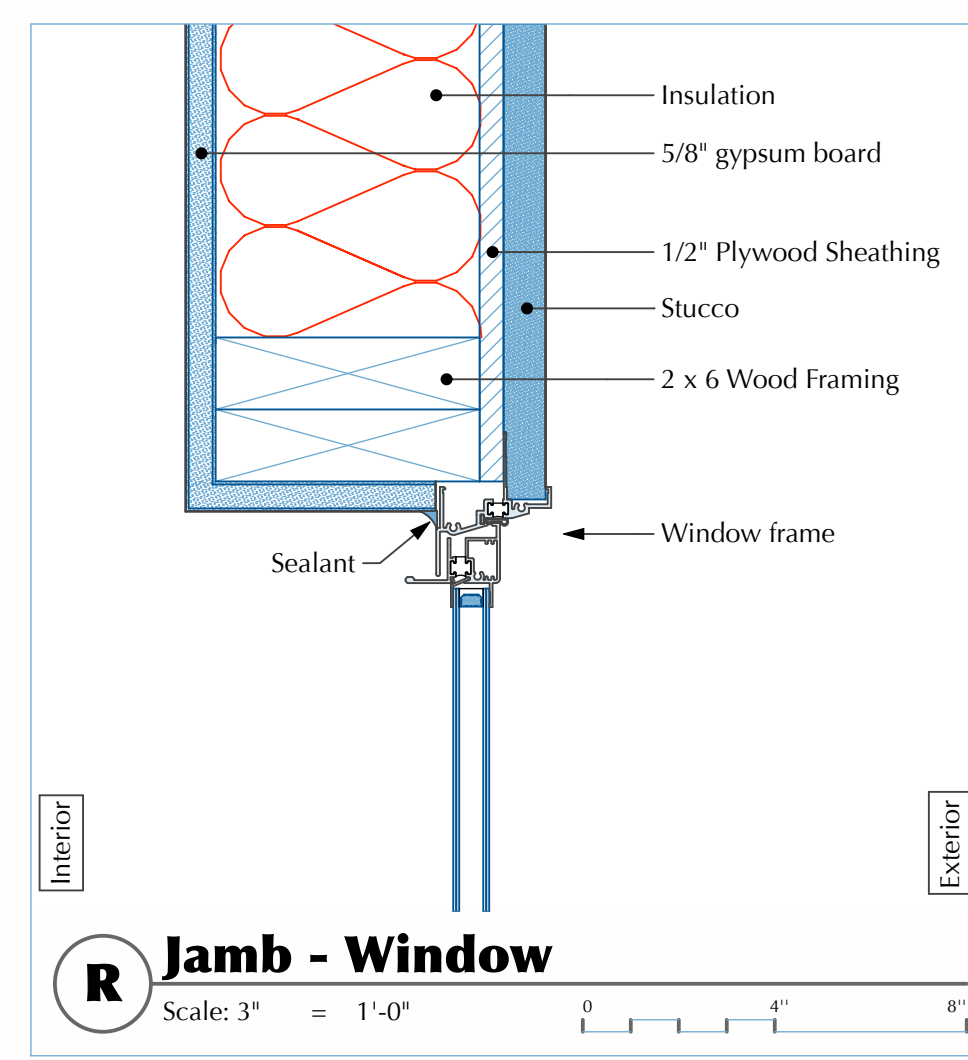

R Jamb - Window
Scale: 3" = 1'-0"

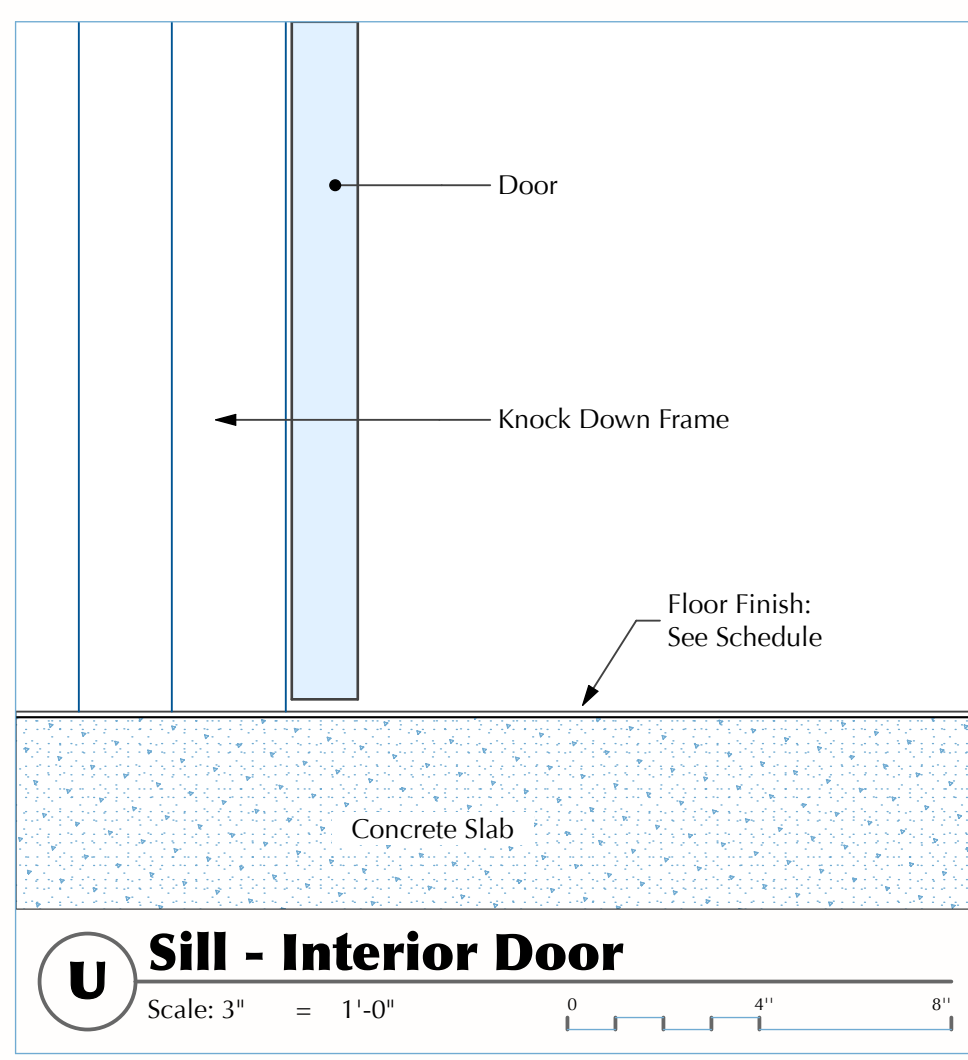

U Sill - Interior Door
Scale: 3" = 1'-0"

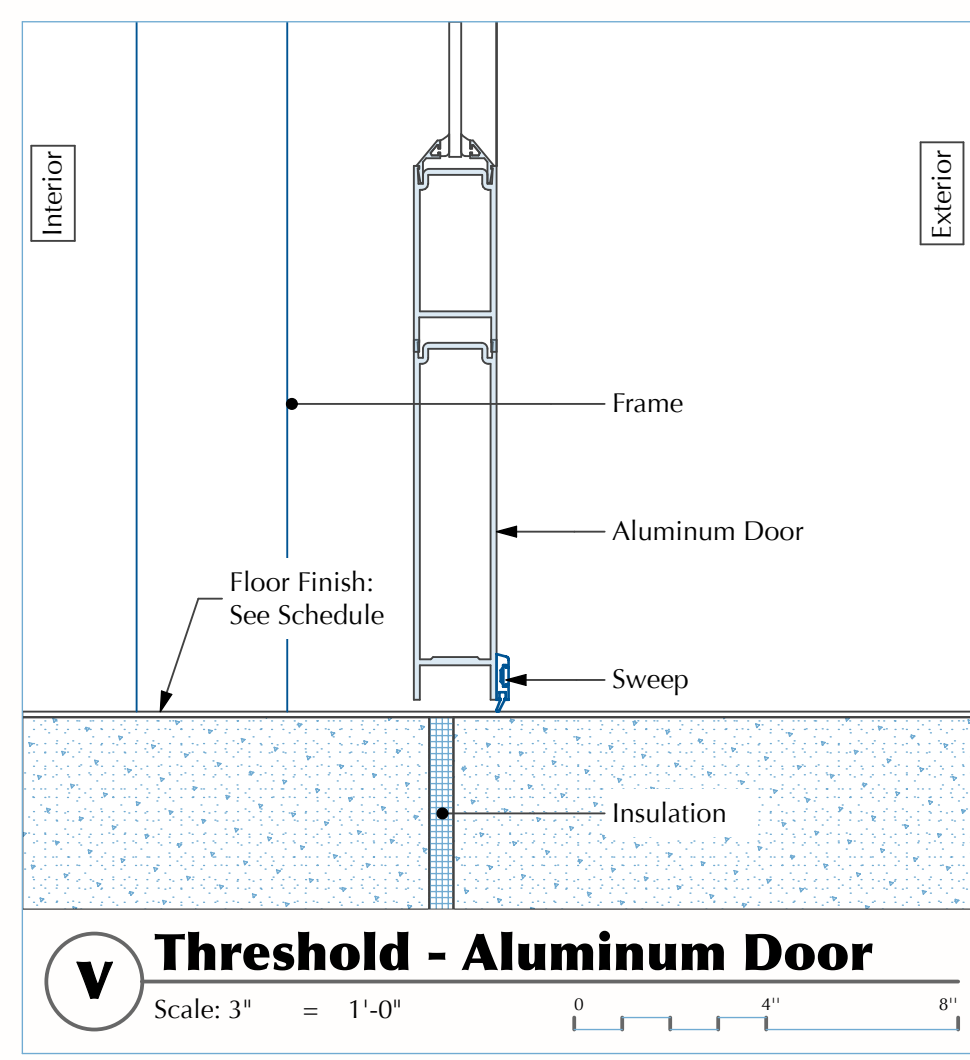

V Threshold - Aluminum Door
Scale: 3" = 1'-0"

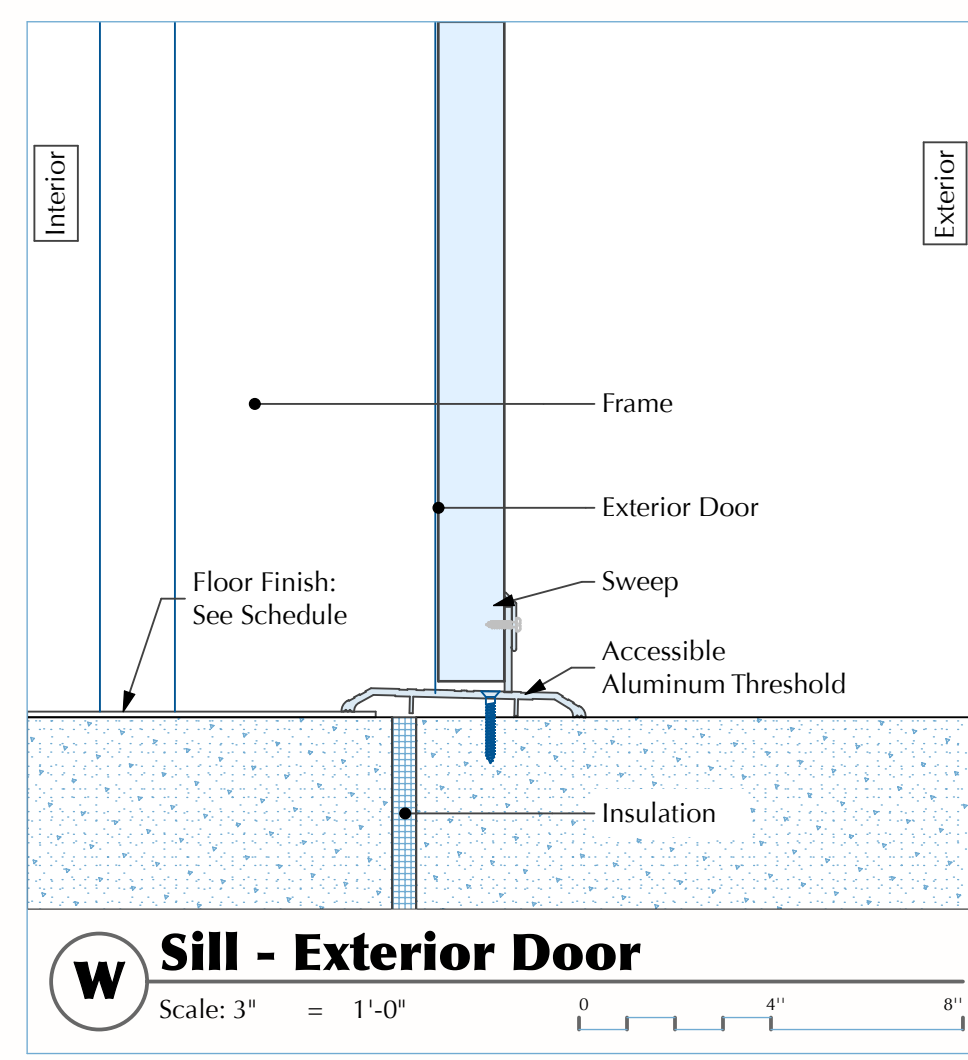

W Sill - Exterior Door
Scale: 3" = 1'-0"

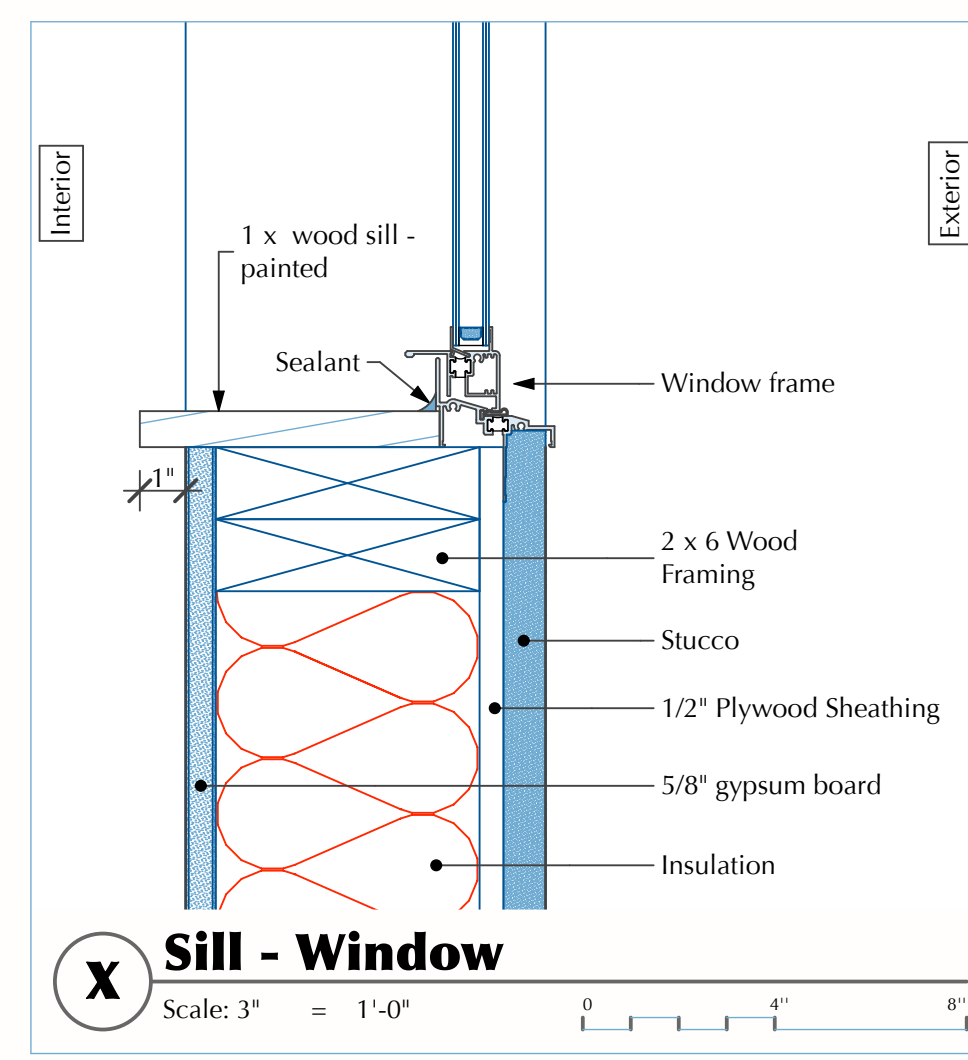

X Sill - Window
Scale: 3" = 1'-0"

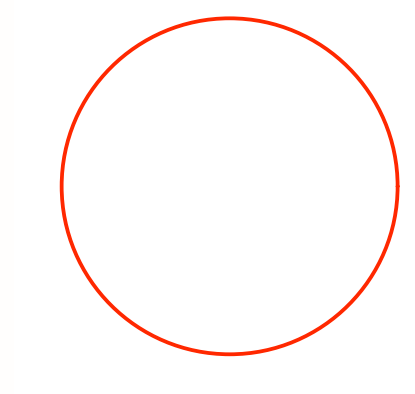

James C Lewis Architect
General Design, Inc.
1620 Central Avenue SE
Albuquerque, NM 87106
(505) 247-1529 • gal@mac.com
Architecture & Planning

Taos Clinic for Children and Youth
1397 Weimer Road
Taos, New Mexico 87571

ISSUE DATE:
22 July, 2008

REVISIONS:

PROJECT # 2007-0713

Details

SHEET
A-501
26 OF 39